



INSTALLATION INSTRUCTIONS

Recessed Mounted, Steel Bath Cabinet

MODEL NO.	OVERALL SIZE		WALL OPENING		
	W	H	W	H	D
820	18	27 1/4	14	18	3 1/2
828	18	27 1/4	14	24	3 1/2
870	18	27 1/4	14	18	3 1/2
830C	17 7/8	33 7/8	14	24	3 1/2
824BC	18	27 1/4	14	24	3 1/2
878BC	18	27 1/4	14	24	3 1/2

MIRROR CARE

- Use only mild cleaning solutions and a clean, soft, lint-free cloth.
- DO NOT USE cleaners that contain strong solutions of ammonia, vinegar, or chlorine.
- DO NOT USE powdered cleansers or steel wool.
- Never spray cleaning agent directly on mirror, especially on exposed edges and mirror backing. Apply cleaner to soft cloth and wipe mirror. Dry mirror thoroughly.
- Keep mirror dry. A well ventilated bath room is important.

INSTALLATION

1. Carefully remove all packing material. Place shelves and hardware package aside until needed.
2. Determine desired location of cabinet on wall. Mark wall to show wall opening size (see dimension chart). Generally, the recommended height to the center of the cabinet is 64" from the floor. Fig. 1
3. Cut wall opening, being careful not to damage the surrounding wall surface. Wall studs, plumbing or electrical lines that interfere must be removed or relocated. Insert framing to support all plaster board edges.
4. Insert cabinet into wall opening in plumb and centered position. Use a carpenter's level and shim corners of cabinet if necessary. Secure to wall studs through the 4 mounting holes inside cabinet (screws provided).
5. Place shelf brackets at desired height. Place shelves on brackets.

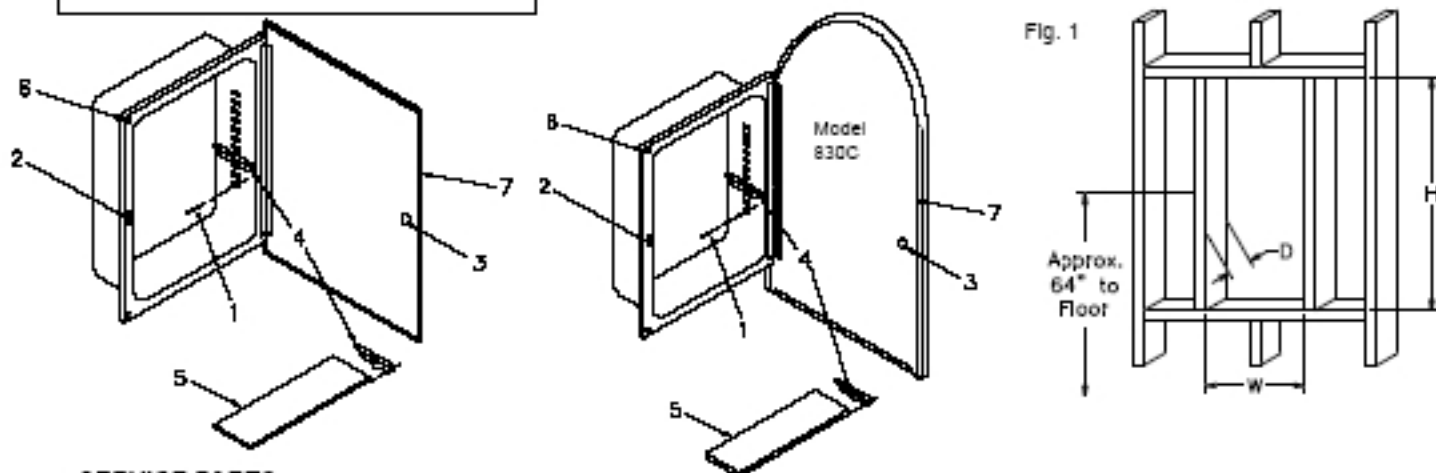

SERVICE PARTS

KEY NO.	DESCRIPTION	PART NUMBER					
		820	828	870	830C	824BC	878BC
1	Mounting screw, #8 x 1 1/2" (4 req.)	97013998	97013998	97013998	97013998	97013998	97013998
2	Magnet	7106	7106	7106	7106	7106	7106
3	Door Strike	A97015555	A97015555	A97015555	A97015555	A97015555	A97015555
4	Shelf Bracket	3330	3330	3330	3330	3330	3330
5	Shelf, glass	A99050235	A99050235	A99050235	A99050235	A99050235	A99050235
6	Bumper	7189	7189	7189	7189	7189	7189
7	Door Assembly	P82000	P82000	P87000	A97016052	A97014987	P87000

* Standard hardware - may be purchased locally.

Order replacement parts by "PART NUMBER," - NOT by "KEY NO."

BROAN-NUTONE ONE YEAR LIMITED WARRANTY

Broan-Nutone warrants to the original consumer purchaser of its product that such products will be free from defects in materials or workmanship for a period of one year from the date of original purchase. THERE ARE NO OTHER WARRANTIES, EXPRESS OR IMPLIED, INCLUDING, BUT NOT LIMITED TO, IMPLIED WARRANTIES OF MERCHANTABILITY OR FITNESS FOR A PARTICULAR PURPOSE. During this one-year period, Broan-Nutone will, at its option, repair or replace, without charge, any product or part which is found to be defective under normal use and service. THIS WARRANTY DOES NOT EXTEND TO FLUORESCENT LAMP STARTERS AND TUBES. This warranty does not cover (a) normal maintenance and service or (b) any product or parts which have been subjected to misuse, negligence, accident, improper maintenance or repair (other than by Broan-Nutone), faulty installation or installation contrary to recommended installation instructions. The duration of any implied warranty is limited to the one-year period as specified for the express warranty. Some states do not allow limitation on how long an implied warranty lasts, so the above limitation may not apply to you. BROAN-NUTONE'S OBLIGATION TO REPAIR OR REPLACE, AT BROAN-NUTONE'S OPTION, SHALL BE THE PURCHASER'S SOLE AND EXCLUSIVE REMEDY UNDER THIS WARRANTY. BROAN-NUTONE SHALL NOT BE LIABLE FOR INCIDENTAL, CONSEQUENTIAL OR SPECIAL DAMAGES ARISING OUT OF OR IN CONNECTION WITH PRODUCT USE OR PERFORMANCE. Some states do not allow the exclusion or limitation of incidental or consequential damages, so the above limitation or exclusion may not apply to you. This warranty gives you specific legal rights, and you may also have other rights, which vary from state to state. This warranty supersedes all prior warranties. To qualify for warranty service, you must (a) notify Broan-Nutone at the address or telephone number stated below, (b) give the model number and part identification and (c) describe the nature of any defect in the product or part. At all time of requesting warranty service, you must present evidence of the original purchase date.

